

# PRODUCT INFORMATION PACKET

Model No: 324TTFCA6013

Catalog No: GT3533

40 HP Close-Coupled Pump Motor, 3 phase, 3600 RPM, 575 V, 324JP Frame, TEFC  
JP Motors





**Nameplate Specifications**

Output HP	<b>40 Hp</b>	Output KW	<b>30.0 kW</b>
Frequency	<b>60 Hz</b>	Voltage	<b>575 V</b>
Current	<b>36.0 A</b>	Speed	<b>3570 rpm</b>
Service Factor	<b>1.15</b>	Phase	<b>3</b>
Efficiency	<b>92.4 %</b>	Power Factor	<b>89.5</b>
Duty	<b>Continuous</b>	Insulation Class	<b>F</b>
Design Code	<b>B</b>	KVA Code	<b>G</b>
Frame	<b>324JP</b>	Enclosure	<b>Totally Enclosed Fan Cooled</b>
Thermal Protection	<b>No</b>	Ambient Temperature	<b>40 °C</b>
Drive End Bearing Size	<b>6212</b>	Opp Drive End Bearing Size	<b>6212</b>
UL	<b>Recognized</b>	CSA	<b>Y</b>
CE	<b>Y</b>	IP Code	<b>43</b>

**Technical Specifications**

Electrical Type	<b>Squirrel Cage Inverter Rated</b>	Starting Method	<b>Line Or Inverter</b>
Poles	<b>2</b>	Rotation	<b>Reversible</b>
Resistance Main	<b>.164 Ohms</b>	Mounting	<b>Rigid Base</b>
Motor Orientation	<b>Horizontal</b>	Drive End Bearing	<b>Ball</b>
Opp Drive End Bearing	<b>Ball</b>	Frame Material	<b>Cast Iron</b>
Shaft Type	<b>JP</b>	Overall Length	<b>35.81 in</b>
Shaft Diameter	<b>1.250 in</b>	Shaft Extension	<b>8.12 in</b>
Assembly/Box Mounting	<b>F1/F2 CAPABLE</b>		
Connection Drawing	<b>EE7300</b>	Outline Drawing	<b>SS620569-324T</b>

This is an uncontrolled document once printed or downloaded and is subject to change without notice. Date Created:20/01/2021

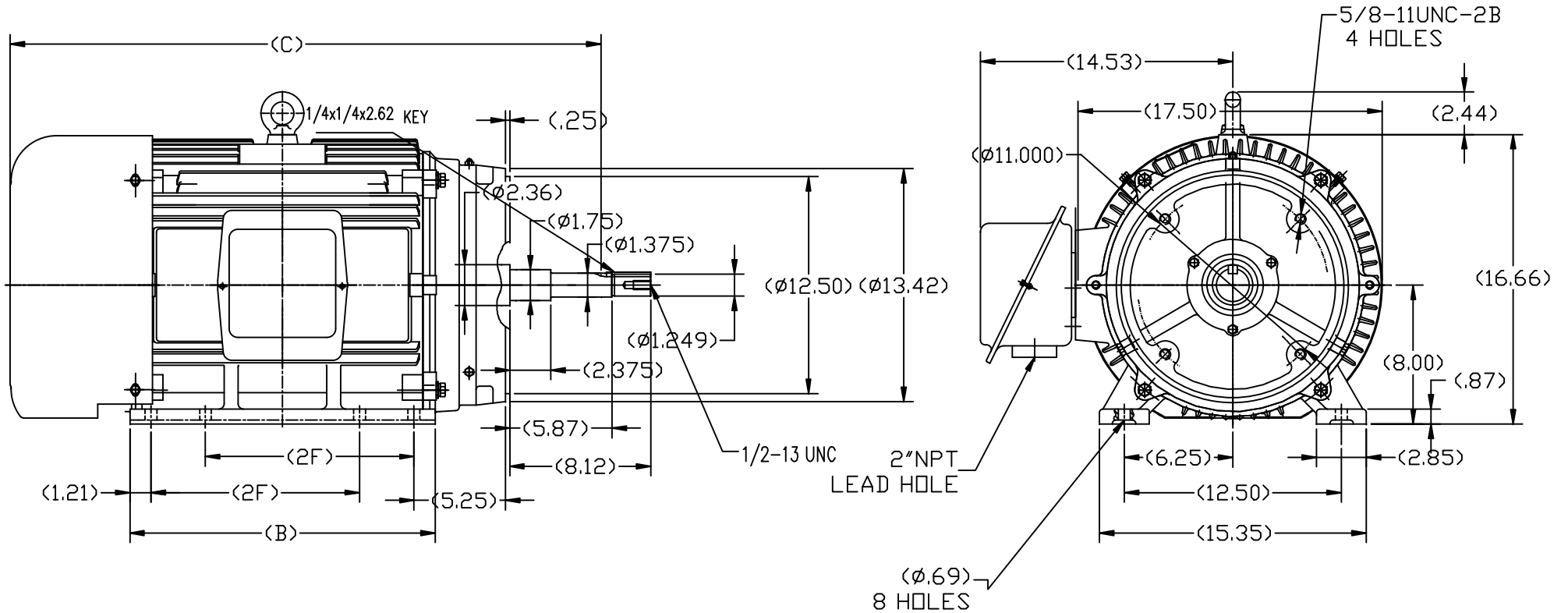

324T	35.81	16.38	10.50
326T	36.99	17.56	12.00
FRAME	C	B	2F

TOLERANCES UNLESS SPECIFIED		REGAL-BELOIT CORPORATION		DRAWN VY 05-23-2012				
DEC.	INCHES			CHK	ZYH 05-23-2012			
.X	±.1	 TITLE OUTLINE TEFC-324/326JP FR-CAST IRON		APPD	WGH 05-23-2012			
.XX	±.03			SCALE	1=7			
.XXX	±.005			REF				
.XXXX	±.0005			FMF	HWADA			
NO.	REVISION	BY & DATE	CHK	ANG	±1/2	FINISH	PREV	
THIS DRAWING IN DESIGN AND DETAIL IS OUR PROPERTY AND MUST NOT BE USED EXCEPT IN CONNECTION WITH OUR WORK ALL RIGHTS OF DESIGN AND INVENTION ARE RESERVED THIS IS AN ELECTRONICALLY GENERATED DOCUMENT - DO NOT SCALE THIS PRINT			RFP	CAD FILE	SS620569	SIZE	DRAWING NO.	REV.
			DIST			B	SS620569	

**THREE PHASE - SINGLE VOLTAGE  
MOTOR - CONDUIT BOX @ 'A'**

**TO REVERSE ROTATION:  
INTERCHANGE ANY TWO  
LINE LEAD CONNECTIONS.**

**TERMINAL BLOCK WHEN SPECIFIED**

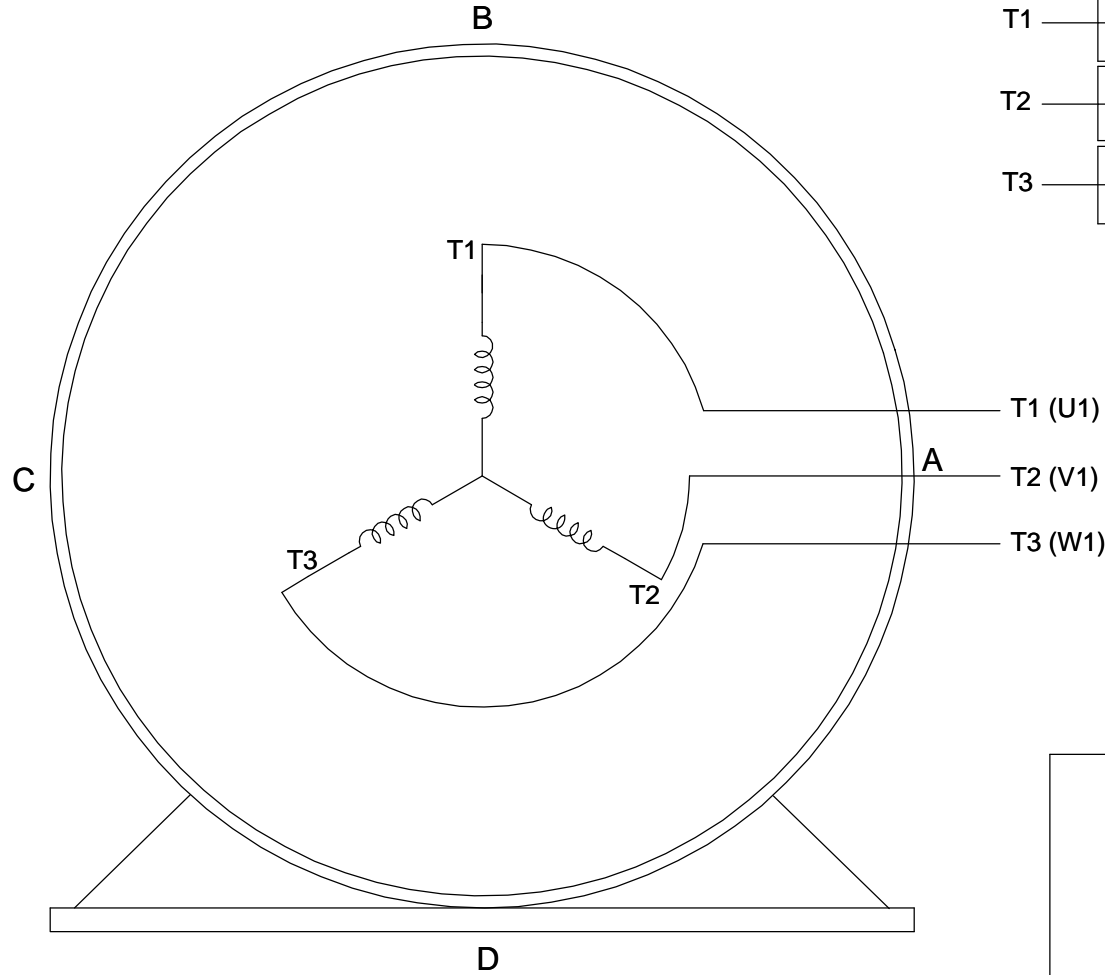
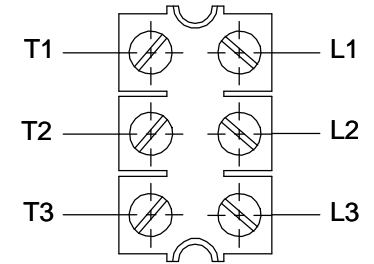

**VIEW OF TERMINAL END**

**IF MOTOR HAS  
6 LEADS**

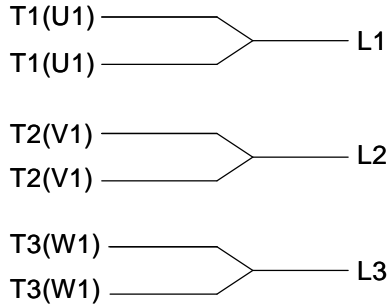

A-9806 DECAL

**OPTIONAL CORD  
CONNECTION**

- L1 \_\_\_\_\_ WHITE \_\_\_\_\_
- L2 \_\_\_\_\_ RED \_\_\_\_\_
- L3 \_\_\_\_\_ BLACK \_\_\_\_\_

DRAWING REVISION AB	REVISION BY JJB	DATE 06-27-2017
ECO ECO-0125361	APPROVED BY TB	DATE 06-27-2017
ECO DESCRIPTION <b>UPDATED TO CURRENT STANDARDS</b>		
<small>COPYRIGHT REGAL BELOIT AMERICA, INC. ALL RIGHTS RESERVED.                  PROPRIETARY AND CONFIDENTIAL INFORMATION - THIS DOCUMENT IS THE PROPERTY OF                  REGAL BELOIT AMERICA, INC. ("OWNER") AND CONTAINS OWNER'S PROPRIETARY                  INFORMATION. ANY PERSON, CORPORATION OR OTHER FIRM RECEIVING IT IS DEEMED,                  BY RECEIVING IT, TO AGREE THAT IT, AND/OR ANY PART OF IT, SHALL NOT BE DISCLOSED                  TO ANY PERSON, CORPORATION OR OTHER ENTITY, DUPLICATED, AND/OR USED, EXCEPT                  AS EXPRESSLY APPROVED IN WRITING IN ADVANCE BY OWNER. THIS DOCUMENT SHALL                  BE RETURNED TO OWNER UPON REQUEST. IT MAY BE SUBJECT TO CERTAIN                  RESTRICTIONS UNDER APPLICABLE EXPORT CONTROL LAWS AND REGULATIONS.</small>		



DRAWN BY DA
DATE 03-26-1993
APPROVED BY TB
DATE 03-26-1993
REFERENCE
THIRD ANGLE PROJECTION

<b>Regal Beloit America, Inc.</b>		
		DESCRIPTION <b>CONNECTION DIAGRAM</b> EXTERNAL - SINGLE VOLTAGE - 3Ø MOTOR
MATERIAL	PROCESS/FINISH	
SIZE <b>A</b>	DRAWING NUMBER <b>EE7300</b>	SHEET 1 OF 1



Data Sheet

Date: 16-06-2017  
 Customer: \_\_\_\_\_  
 Attention: \_\_\_\_\_  
 Submitted by: FAREEDA DUDEKULA



324TFCA6013

Submittal

Data @ 575 V

Motor Load Data

Load	0%	25%	50%	75%	100%	115%	125%	LR
Current (Amps)	9.8	13.4	20.0	28.0	35.2	40.8	44.8	216
Torque (ft-lb)	0.00	14.6	29.3	44.0	59.0	68.0	74.0	85.0
RPM	3600	3592	3582	3575	3570	3560	3550	0
Efficiency (%)		87.5	91.7	93.0	92.4	92.4	91.7	
P.F. (%)	8.5	64.0	81.5	87.0	90.0	90.0	90.0	30.0

Motor Speed Data

	LR	Pull-Up	BD	Rated	Idle
Speed (RPM)	0	1800	3450	3570	3600
Current (Amps)	216	194	126	35.2	9.8
Torque (ft-lb)	85.0	73.0	135	59.0	0.00

Information Block

HP	40.0			
Sync. RPM	3600			
Frame	324			
Enclosure	TEFC			
Construction	TFC			
Voltage	575 V			
Frequency	60 Hz			
Design	B			
LR Code letter	G			
Service Factor	1.15			
Temp Rise @ FL	60 ° C			
Duty	CONT			
Ambient	40 ° C			
Elevation	1,000 feet			
Rotor/Shaft wk <sup>2</sup>	4.8 Lb-Ft <sup>2</sup>			
Ref Wdg	CHT32420004 NONE			
Sound Pressure @ 1M	75 dBA			
VFD Rating	VARIABLE 10:1			
Outline Dwg	SS620569			
Conn. Diag	EE7300			
Additional Specifications:				
0				
365THFS8036				
EQUIV CKT (OHMS / PHASE)				
R1	R2	X1	X2	Xm
0.1880	0.0980	0.9420	0.9970	34.0150

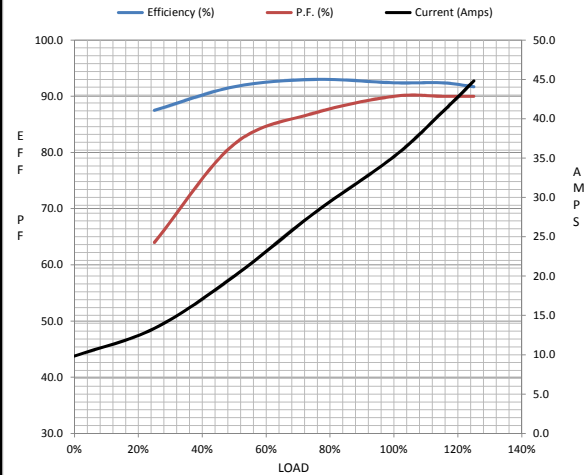

Speed -Torque Curve

